

TREAD DETAIL

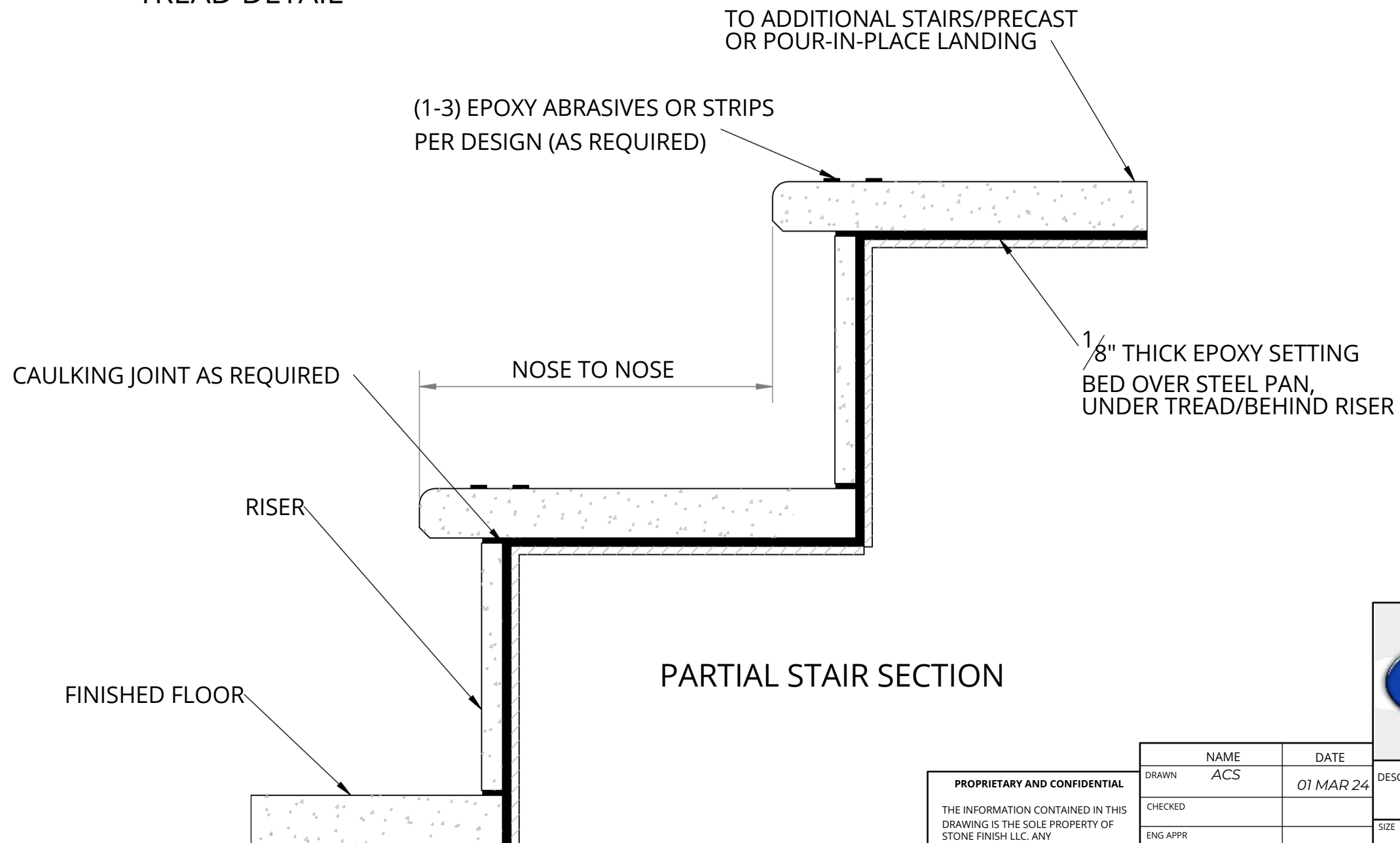
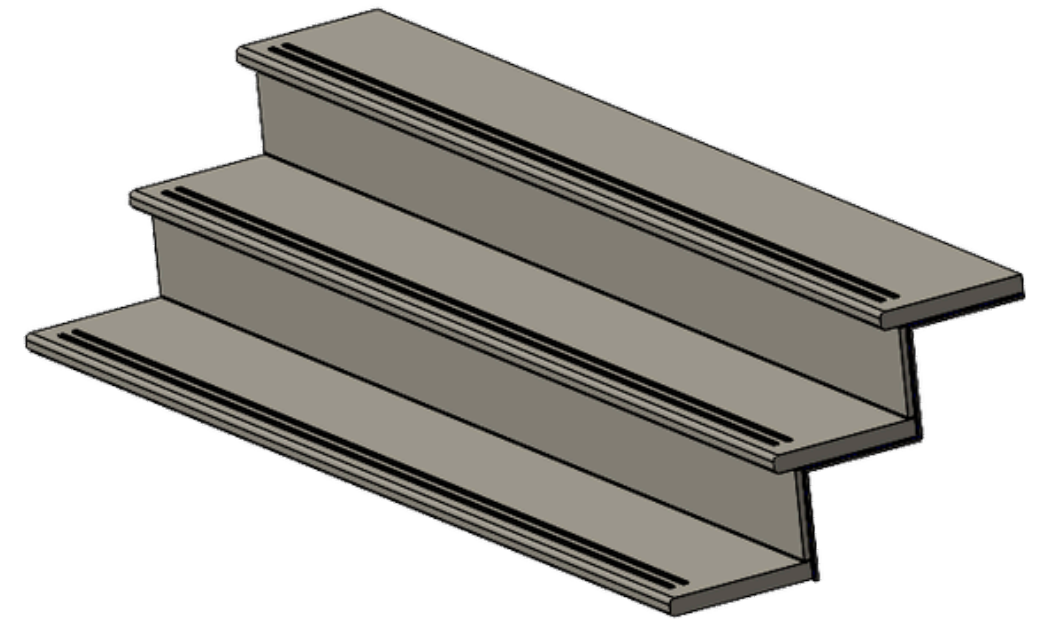

**PROPRIETARY AND CONFIDENTIAL**

THE INFORMATION CONTAINED IN THIS DRAWING IS THE SOLE PROPERTY OF STONE FINISH LLC. ANY REPRODUCTION IN PART OR AS A WHOLE WITHOUT THE WRITTEN PERMISSION OF STONE FINISH IS PROHIBITED.

NAME	DATE
DRAWN ACS	01 MAR 24
CHECKED	
ENG APPR	
MFG APPR	

DESCRIPTION		TREAD & RISER	
SIZE	DRAWING NUMBER	REV	
B	TRO2	A	
SCALE:	1:5	SHEET	1 OF 1